



POLYSCOPE

fresh thinking, great products

XIRAN[®] IN AUTOMOTIVE APPLICATIONS

www.polyscope.eu

XIRAN® SMA/ABS compounds key properties

Material property	Application advantage
High functionality	Excellent foam and paint adhesion without surface treatment
Low shrinkage	Precision molding in big parts and low warpage, predictable and easy tool design and production
Low CLTE	Precise gap conditions and insert molding
Excellent creep resistance	High screw torque retention
Good thermal stability	Constant properties over broad temperature range
High modulus	High stiffness and strength
Low thermal conduction	Excellent insulation properties
Easy processability	High productivity and short cycle times

XIRAN® grades

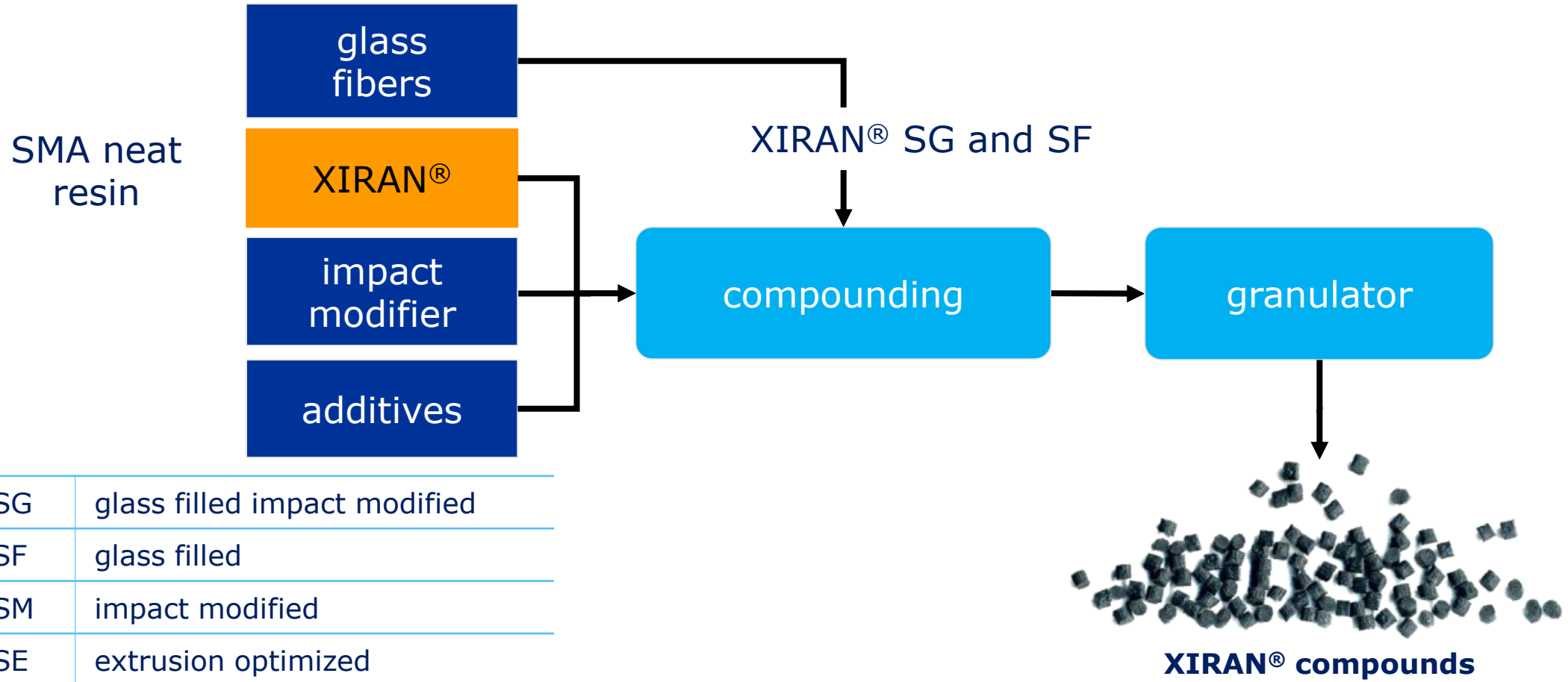

SG	glass filled impact modified
SF	glass filled
SM	impact modified
SE	extrusion optimized

XIRAN® in automotive applications

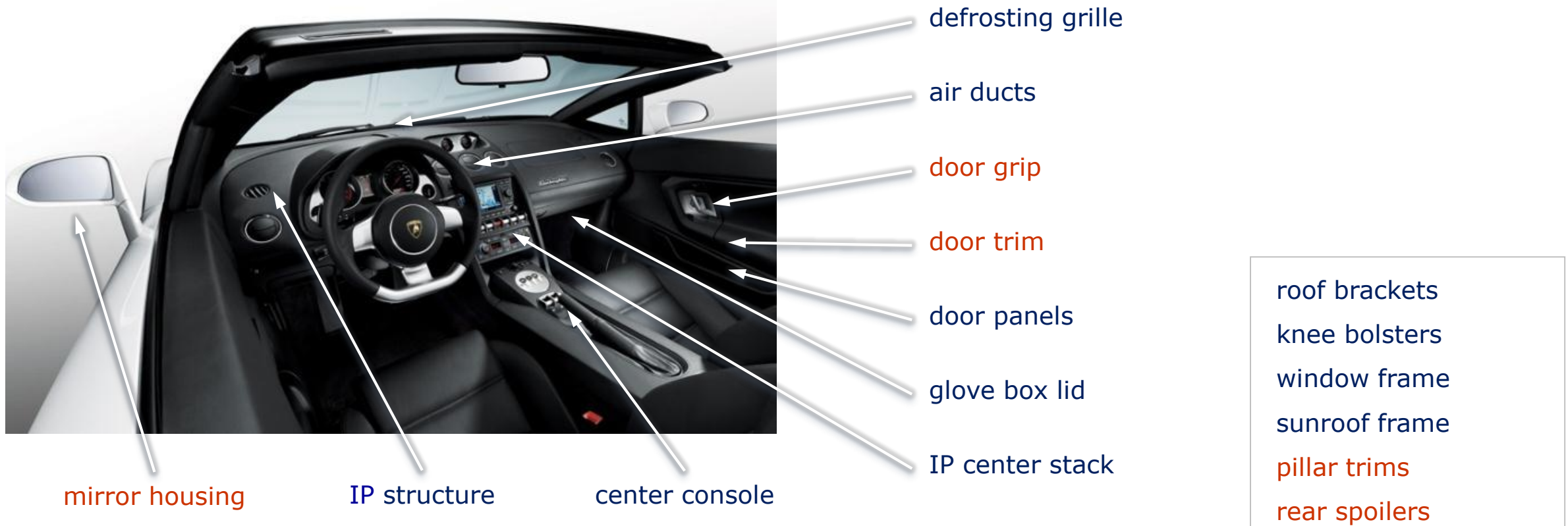

- XIRAN® SM200, SM400, SM500 for interior trim
- XIRAN® SG230, SG226, SG260 for structural parts

XIRAN® applications



instrument panel



sunroof frame



demister panel



center stack



air duct



door trim

Roller-blind sunroof modules Renault Grand Scenic: running applications

- **XIRAN® SG230:**
 - Impact modified and 15% glass fibers
- Benefits (compared to aluminum)
 - Stiff, strong, low density, very low warpage, low thermal deformation
 - No post-mold crystallization, good weldability, easy recycling
 - High bond strength to urethane adhesive that joins glass to sunroof module
 - 20% cost savings by going from 7 to 2 steps in the manufacturing process

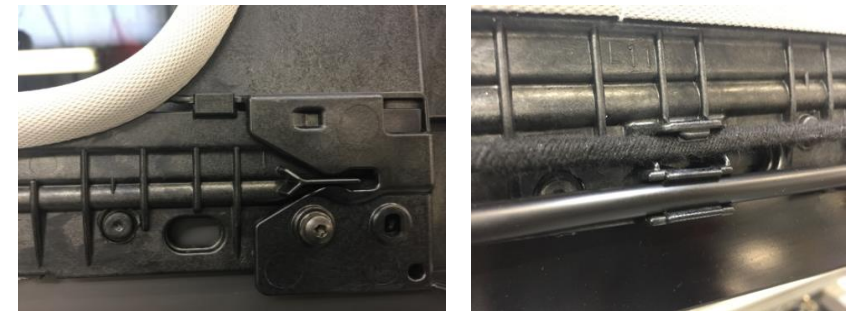

Sunroof frame Citroen DS3 Cabrio: running applications

- **XIRAN® SGH30EB:**
 - Impact modified and 15% glass fibers
- Benefits (compared to PBT/ASA-GF and SMC)
 - Good surface adhesion to PU glue
 - Dimensional stability and accuracy
 - Low CLTE, low warpage, no tool adjustment
 - Low shrinkage: easy mold (tool) design and production (highly predictable)
- XIRAN® sunroof parts at VW-Audi, PSA, Renault, Land Rover, BMW, Scania, Mitsubishi and other major OEM's



Side window frame VW Crafter: running applications

- **XIRAN® SG230EB-B:**
 - Impact modified and 15% glass fibers
- **Benefits**
 - Excellent surface adhesion to glue and paint
 - Good stiffness (flexural modulus 5400 MPa)
 - High dimensional accuracy
 - Low CLTE, low shrinkage: easy mold (tool) design and production
 - High temperature resistance (HDT > 120°C)
 - Sun exposure resistance



Soft instrument panel carrier

- **XIRAN® SG230:**
 - Impact modified and 15% glass fibers
- **Benefits (compared to PP-LG)**
 - Excellent surface adhesion to foam and paint
 - Good stiffness (flexural modulus 5400 MPa)
 - Dimensional stability
 - Low CLTE: easy to combine with similar CLTE of metals
 - Low shrinkage: easy mold (tool) design and production (highly predictable and no need for prototype tooling)
 - High temperature resistance (HDT > 120°C)

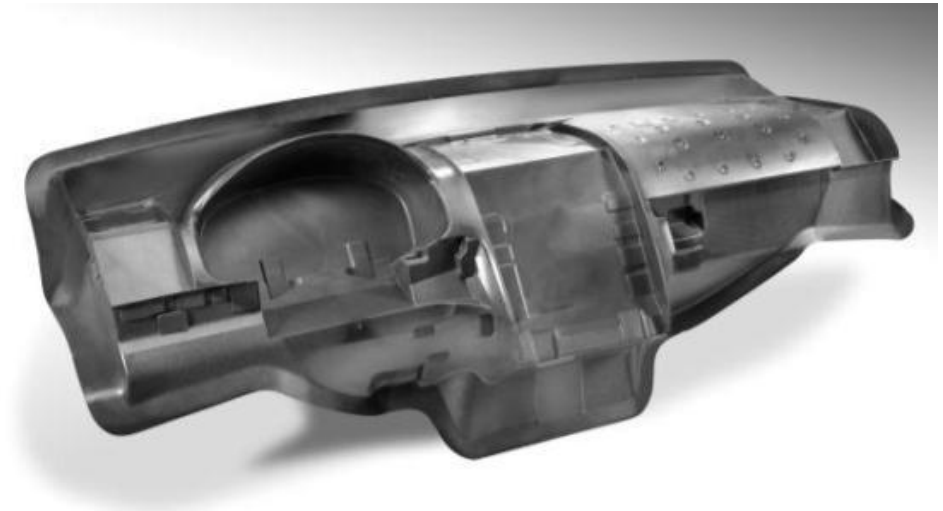

Door panel structure

- **XIRAN® SG230:**
 - Impact modified and 15% glass fibers
- **Benefit**
 - Excellent surface adhesion to foam
 - High stiffness (flexural modulus 5400 MPa)
 - Dimensional stability
 - Low CLTE: perfect fit with metals
 - Low shrinkage: easy mold design
 - Significant weight savings



Sunroof frame: XIRAN® compared to alternatives

- Due to amorphous nature of XIRAN® compounds, warpage is almost zero
- Semi-crystalline materials always have a high warpage

XIRAN® SG260
30% GF
no warpage

Polypropylene
30% GF
high warpage



source: IAC group

Recycled XIRAN® properties

- Excellent retention of properties
- Comparison of 100% virgin material and 20% recycled blend

Property			100/0	80/20	Delta
MFR 220/10	ISO 1122	dg/min	5.9	6.7	14%
Charpy 23°C unnotched	ISO 179	kJ/m ²	27.0	26.7	-1%
Charpy 23°C notched	ISO 179	kJ/m ²	8.8	8.5	-3%
Charpy -40°C unnotched	ISO 179	kJ/m ²	31.0	30.5	-2%
Charpy -40°C notched	ISO 179	kJ/m ²	7.5	7.4	-1%
Flexural modulus	ISO 178	MPa	4900	4824	-2%
Flexural strength	ISO 178	MPa	113.0	111.8	-1%
HDT 1.80 MPa	ISO 75	°C	118.0	117.7	0%
Spiral flow		mm	323	320	-1%

Any questions?



All information supplied by or on behalf of the Polyscope in relation to its products, whether in the nature of data, recommendations or otherwise, is supported by research and believed reliable, but Polyscope assumes no liability whatsoever in respect of application, processing or use made of the afore mentioned information or products, or any consequence thereof. The user undertakes all liability in respect to the application, processing or use of the afore-mentioned information or product, whose quality and other properties he shall verify, or any consequence thereof. No liability whatsoever shall attach to Polyscope for any infringement of the rights owned or controlled by a third party in intellectual, industrial or property by reason of the application, processing or use of the afore-mentioned information or products by the user.